

## TRADITIONAL OVEN JOY STATIC MONOBLOCK COOKTOP

90

This Monoblock auto-dilating backing oven is recommended for restaurants seating a maximum of 20 people or for anyone who simply wish to give an extra service to the customers without losing space. Ideal for cooking pizza at home or in the garden with the help of a professional oven.

Exceptional performance, compact size, power consumption in line with our traditional ovens, perfect baking for the entire evening. Designed to provide a working tool of the highest standard but still unique, because it is strongly characterized in terms of aesthetics, almost a piece of design.

The oven Joy 90 is supplied with a one-torch manual burner Drago P1.

Inside Dimentions	cm	86x81
Weight	Kg.	300
Dome Thickness	cm	8
Cook Top - Cover Distance	cm	40
Cook top height from ground	cm	116
Base Insulation Thickness (Microporous Panels)	cm	10
Dome Insulation Thickness (Kaolin Blanket)	cm	12
Chimney Flue Ø	cm	14,5/15
Smokes temperature at the vent		300° - 25 g/sec (50m³/Hr)
Static pressure	Pa	12
Monoblock Cooking Plate		Burner Drago P1
Thermal Potential	Kw	min. 6 - max. 10
Thermal Potential	Kcal/h	min. 5.000 - max. 13.000
Gas Pressure Nat. Gas	mbar	min. 15/25 - max. 25/50
Gas Flow Nat. Gas	Nm³/h	min. 0,63/0,20 max. 1,58/0,54
Gas Coupling	inches	1/2
Weight	kg.	Kg. 4
Electrical Power Supply		-
Burner Consumption		-

Because Pavesi oven is hand made and assembled, slight variations in the measures of the final product are normal

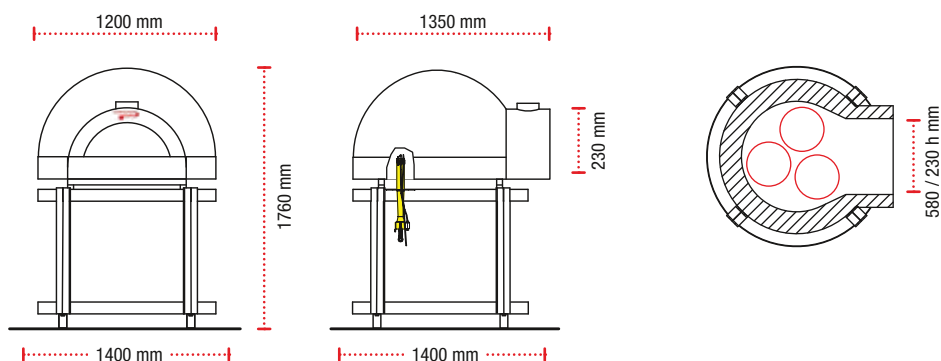

JOY 90



n° 2/3